

UF15AC series

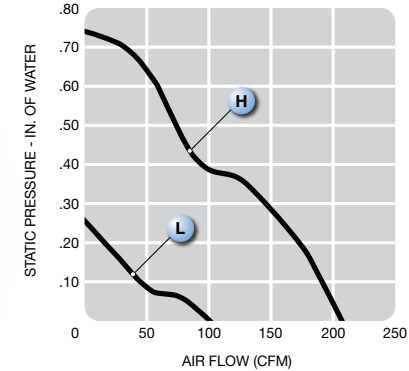
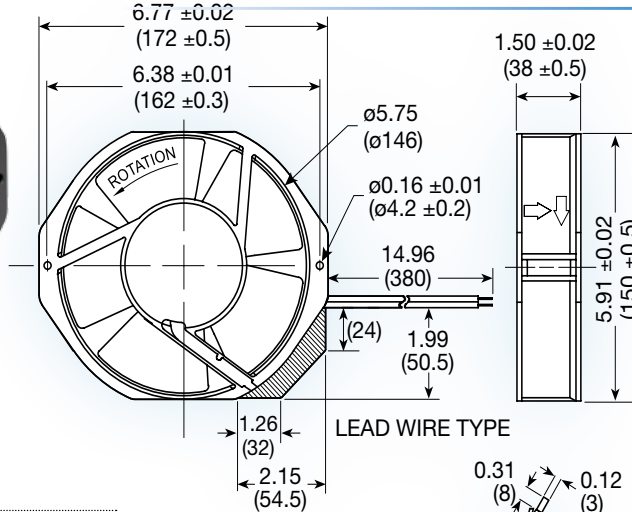

(172 x 150 x 38 mm)
6.77 x 5.91 x 1.50 inches

Operating voltage: 115 or 230 VAC

Construction: aluminum die cast frame;
UL94V-0 PBT impeller

Bearing option: ball bearing

Motor: permanent split capacitor

Air Flow: exhaust over struts

Connection: terminal or 22 AWG lead wire

Protection: thermal

Option: tachometer output

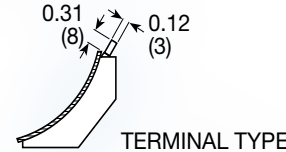

Model No.	Rated Voltage V	Freq. HZ	Input Power W	Rated Cur. A	Locked Cur. A	Speed RPM	Air Volume		Max. Static Pressure (H ₂ O)		Sound Noise dbA	Weight kg
							M ³ /Min.	CFM	MM	INCH		
UF15AC12-__H	115	60	28	0.23	0.38	3,400	6.0	212	19.0	0.75	58	0.72
UF15AC23-__H	230	60	26	0.11	0.18	3,400	6.0	212	19.0	0.75	58	0.72
UF15AC12-__L	115	60	28	0.15	0.20	1,700	2.9	103	6.5	0.26	44	0.72
UF15AC23-__L	230	60	26	0.07	0.10	1,700	2.9	103	6.5	0.26	44	0.72