



■ Features

- Medical (2 x MOPP) safety approval
- Suitable for BF application with appropriate system consideration (Touch current < 100uA/264VAC)
- 1U low profile
- Universal AC input / Full range
- Output voltage and current programmable
- Built-in parallel function / output programmable / global enable / remote local ON-OFF / auxiliary DC output / over temperature alarm / DC OK
- Cooling by thermostatically controlled fan with fan alarm function
- Protections: Short circuit / Overload / Over voltage / Over temperature for all output modules
- 5 years warranty

■ Description

NMP family is a 1U low profile modular power (or, configurable type power supply) from MEAN WELL. This family comprises two power wattage for the line-up, 650W and 1200W, and the output modules deliver up to 240W with adjust options for the major working voltages used in industry 5V, 12V, 24V, 48V. NMP family is complied with safety approval, the medical standard (2 x MOPP between primary to secondary) offering the best flexibility for various types of applications.

■ Applications

- Medical equipment
- Diagnostic or biological facilities
- MRI, CT and PET scanners
- Test or measurement systems
- Telecommunication equipment
- Factory facility and aging equipment
- Laser equipment



650W/1200W Modular Power

NMP series

SPECIFICATION

Front-End

MODEL		NMP650 (4-Slots)		NMP1K2 (6-Slots)		
INPUT	VOLTAGE RANGE <small>Note.5</small>	90 ~ 264VAC 120 ~ 370VDC				
	FREQUENCY RANGE	47 ~ 63Hz				
	POWER FACTOR	PF>0.95/230VAC PF>0.98/115VAC at full load				
	EFFICIENCY(Typ.) <small>Note.4</small>	91%, full case load with H / K module at nominal 24V / 48V only 87%, full case load with each type of module at nominal voltage				
	AC CURRENT	3.5A/230VAC	7.5A/115VAC	6.7A/230VAC	13.5A/115VAC	
	INRUSH CURRENT	40A/230VAC	25A/115VAC	40A/230VAC	25A/115VAC	
	LEAKAGE CURRENT	Earth leakage current <300uA / 264VAC, Touch current <100uA/264VAC				
OUTPUT	TOTAL OUTPUT POWER	650W max.		1200W max.		
PROTECTION	OVER TEMPERATURE	Shut down o/p voltage, recovers automatically after temperature goes down				
	REMOTE CONTROL	RC+/RC-: Short, Power ON RC+/RC-: Open, Power OFF				
FUNCTION	ALARM SIGNAL	TTL signal output for over temperature alarm. Please refer to the Function Manual.				
	AUXILIARY POWER(AUX)	5V @ 1.5A ; tolerance ±10% , ripple : 50mVp-p(max.)		5V @ 2A ; tolerance ±10% , ripple : 50mVp-p(max.)		
ENVIRONMENT	WORKING TEMP.	-30 ~ +70°C (Derate at 50°C, refer to "Derating Curve")				
	WORKING HUMIDITY	20 ~ 90% RH non-condensing				
	STORAGE TEMP., HUMIDITY	-40 ~ +85°C, 10 ~ 95% RH non-condensing				
	TEMP. COEFFICIENT	±0.03%/°C (0 ~ 50°C)				
	VIBRATION	10~500Hz, 2G 10min./1 cycle, 60 min. each along X, Y, Z axes.				
SAFETY & EMC (Note 5)	SAFETY STANDARDS	ANSI/AAMI ES60601-1, TUV EN60601-1, IEC 60601-1 (3 rd edition) approved; Design refer to UL62368-1, TUV EN62368-1				
	ISOLATION LEVEL	Primary-Secondary: 2xMOPP, Primary-Earth: 1xMOPP				
	WITHSTAND VOLTAGE	I/P-O/P:4KVAC I/P-FG:2KVAC O/P-FG:0.5KVAC				
	ISOLATION RESISTANCE	I/P-O/P, I/P-FG, O/P-FG:100M Ohms / 500VDC / 25°C / 70% RH				
	EMC EMISSION	Parameter		Standard		Test Level / Note
		Conducted		EN55032 (CISPR32) / EN55011 (CISPR11)		Class B
		Radiated		EN55032 (CISPR32) / EN55011 (CISPR11)		Class B
		Harmonic Current		EN61000-3-2		Class A
	Voltage Flicker		EN61000-3-3		-----	
	EMC IMMUNITY	EN60601-1-2, EN55024				
Parameter		Standard		Test Level / Note		
ESD		EN61000-4-2		Level 4, 15KV air ; Level 4, 8KV contact		
RF field		EN61000-4-3		Level 2, 3V/m		
EFT / Burst		EN61000-4-4		Level 3, 2KV		
Surge		EN61000-4-5		Level 4, 4KV/Line-FG ; 2KV/Line-Line		
Conducted		EN61000-4-6		Level 2, 3V		
Magnetic Field		EN61000-4-8		Level 4, 30A/m		
Voltage Dips and Interruptions		EN61000-4-11		100% dip 1 periods, 30% dip 25 periods, 100% interruptions 250 periods		
OTHERS	DIMENSION	250*89*41mm (L*W*H)		250*127*41mm (L*W*H)		
	PACKING	1.45Kg(typ.); 9pcs / 14Kg / 0.98CUFT		2Kg(typ.); 6pcs / 13Kg / 0.88CUFT		



■ Output Module (240W)

	MODEL	NMS-240-05	NMS-240-12	NMS-240-24	NMS-240-48
OUTPUT (NS-240)	CONFIGURATION CODE	C	E	H	K
	DC VOLTAGE	5V	12V	24V	48V
	RATED CURRENT	36A	20A	10A	5A
	CURRENT RANGE	0 ~ 36A	0 ~ 20A	0 ~ 10A	0 ~ 5A
	RATED POWER	180W	240W	240W	240W
	RIPPLE & NOISE (max.) Note.2	100mVp-p	150mVp-p	150mVp-p	250mVp-p
	VOLTAGE ADJ. RANGE	3 ~ 6V	6~15V	15~30V	30~55V
	VOLTAGE TOLERANCE Note.3	±2.0%	±1.0%	±1.0%	±1.0%
	LINE REGULATION	±0.5%	±0.3%	±0.2%	±0.2%
	LOAD REGULATION	±1.0%	±0.5%	±0.5%	±0.5%
SETUP, RISE TIME	1500ms, 60ms at full load				
HOLD UP TIME(Typ.)	16ms/230VAC @ 75% total output power 10ms/230VAC @ total output power				
PROTECTION	OVERLOAD	105 ~ 125% rated output power Protection type : constant current limiting protection			
	OVER VOLTAGE	6.1 ~ 7.5V	15.1 ~ 20V	30.1 ~ 37V	56 ~ 66V
	OVER TEMPERATURE	Shut down o/p voltage, recovers automatically after temperature goes down Protection type : Shut down o/p voltage, re-power on to recover			
FUNCTION	REMOTE ON/OFF CONTROL	RC+/RC-: Open, Power ON RC+/RC-: Short, Power OFF			
	REMOTE SENSE	Compensate voltage drop on the load wiring up to 0.5V.			
	OUTPUT VOLTAGE PROGRAMMABLE(PV)	3 ~ 6V	6 ~ 15V	15 ~ 30V	30 ~ 55V
	OUTPUT CURRENT PROGRAMMABLE(PC)	Adjustment of output voltage is allowable. Please refer to the Function Manual.			
	AUXILIARY POWER(AUX)	5V@10mA ; tolerance ±10%, ripple : 50mVp-p(max.)			
	CURRENT SHARING(CS)	Please refer to the Function Manual.			
	DC OK SIGNAL	Output modules turn on=4.5 ~ 5.5V, turn off=0 ~ 0.5V. Please refer to the Function Manual.			
OTHERS	DIMENSION	118.5*37.9*18mm (L*W*H)			
	PACKING	0.142Kg(typ.); 72pcs / 11.2Kg / 1.04CUFT			
NOTE	<p>1. All parameters NOT specially mentioned are measured at 230VAC input, rated load and 25°C of ambient temperature.</p> <p>2. Ripple & noise are measured at 20MHz of bandwidth by using a 12" twisted pair-wire terminated with a 0.1uf & 47uf parallel capacitor.</p> <p>3. Tolerance : includes set up tolerance, line regulation and load regulation.</p> <p>4. NMP650 : The efficiency changes by installing different output modules. The following combination is chosen when fitting different types of module: 5V(Voltage code C)*1, 12V(Voltage code E)*1, 24V(Voltage code H)*1, 48V(Voltage code K)*1.(650W max.) NMP1K2: The efficiency changes by installing different output modules. The following combination is chosen when fitting different types of module: 5V(Voltage code C)*1, 12V(Voltage code E)*1, 24V(Voltage code H)*2, 48V(Voltage code K)*2.(1200W max.) The hold up time of the combination above is 16ms/230vac @ 75% total output power · 10ms/230VAC @ total output power.</p> <p>5.De-rating may be needed under low input voltages. Please check the derating curve for more details.</p> <p>6.Under parallel operation ripple of the output voltage may be higher than the SPEC at light load condition.</p> <p>7.The ambient temperature derating of 3.5°C/1000m with fanless models and of 5°C/1000m with fan models for operating altitude higher than 2000m(6500ft).</p>				



650W/1200W Modular Power

NMP series

■ BLOCK DIAGRAM

NMP1K2 & NMP650

PFC fosc : 85KHz(NMP1K2)
 70KHz(NMP650)
 PWM fosc : 100KHz

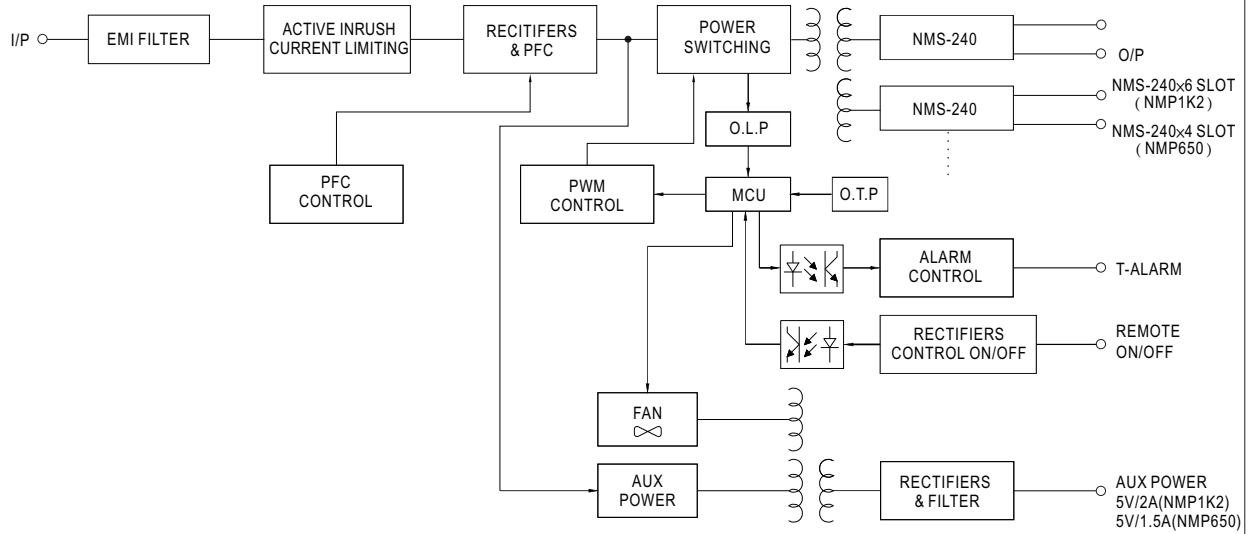

NMS-240

PWM fosc : 175KHz

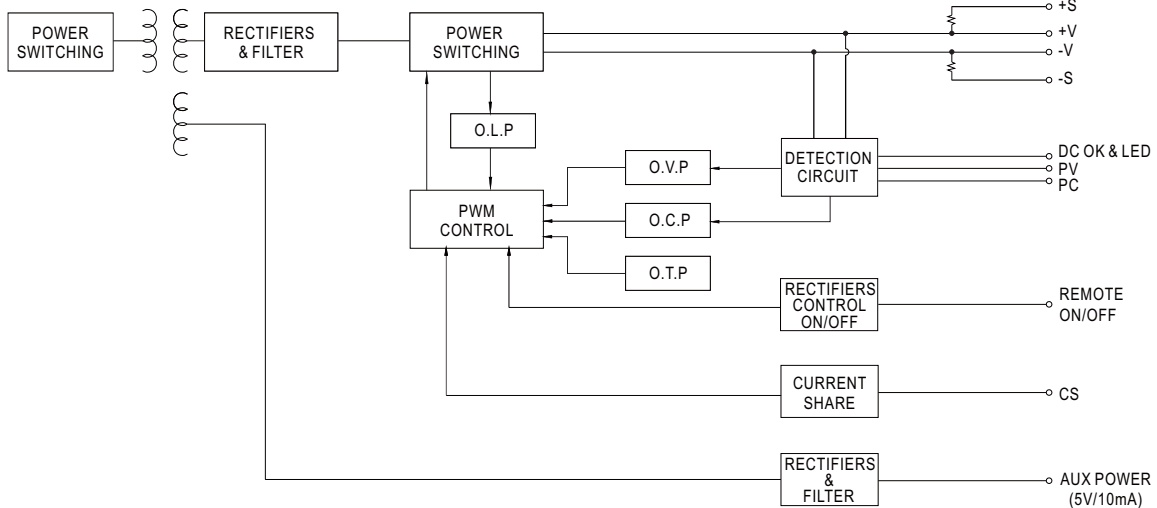

Derating Curve

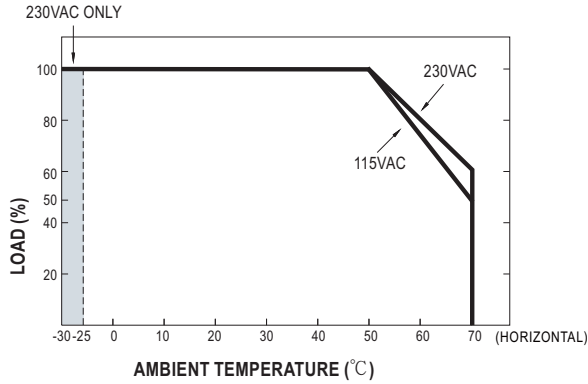

Static Characteristics

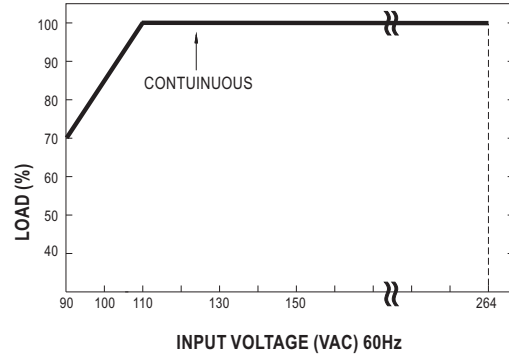

MECHANICAL SPECIFICATION

※NMP1K2

Case No.260 Unit:mm

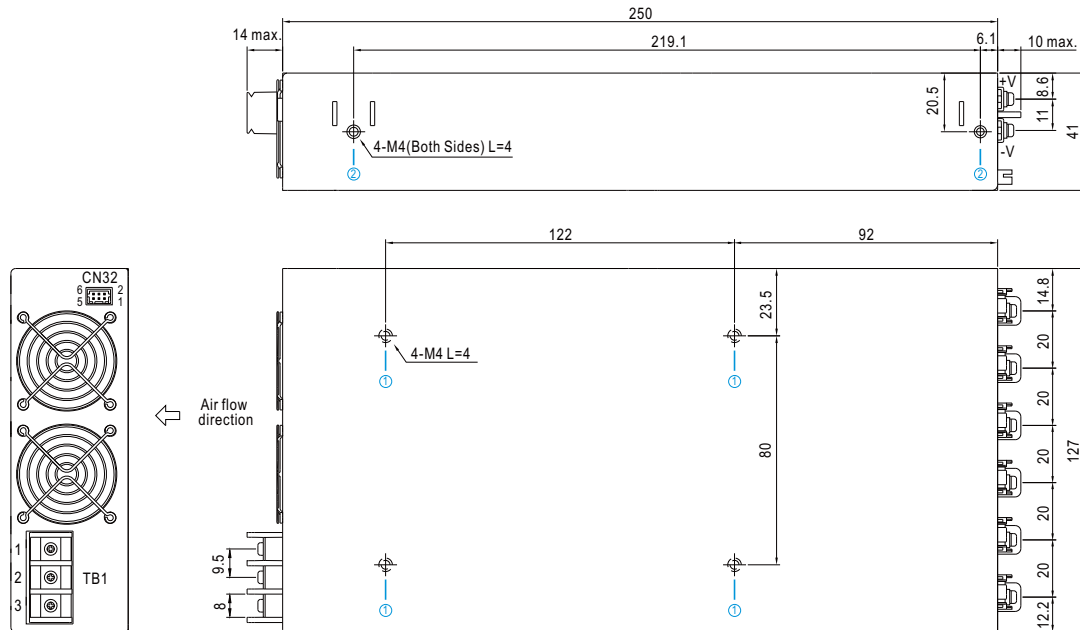

※ Mounting Instruction

Hole No.	Recommended Screw Size	MAX. Penetration Depth L	Recommended mounting torque
①	M4	4mm	7~10Kgf-cm
②	M4	4mm	7~10Kgf-cm

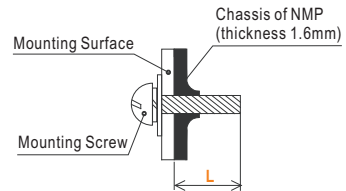

※AC Input Terminal Pin No. Assignment

Pin No.	Assignment	Diagram	Maximum mounting torque
1	FG \perp		12Kgf-cm
2	AC/N		
3	AC/L		

MECHANICAL SPECIFICATION

※NMP650

Case No.259 Unit:mm

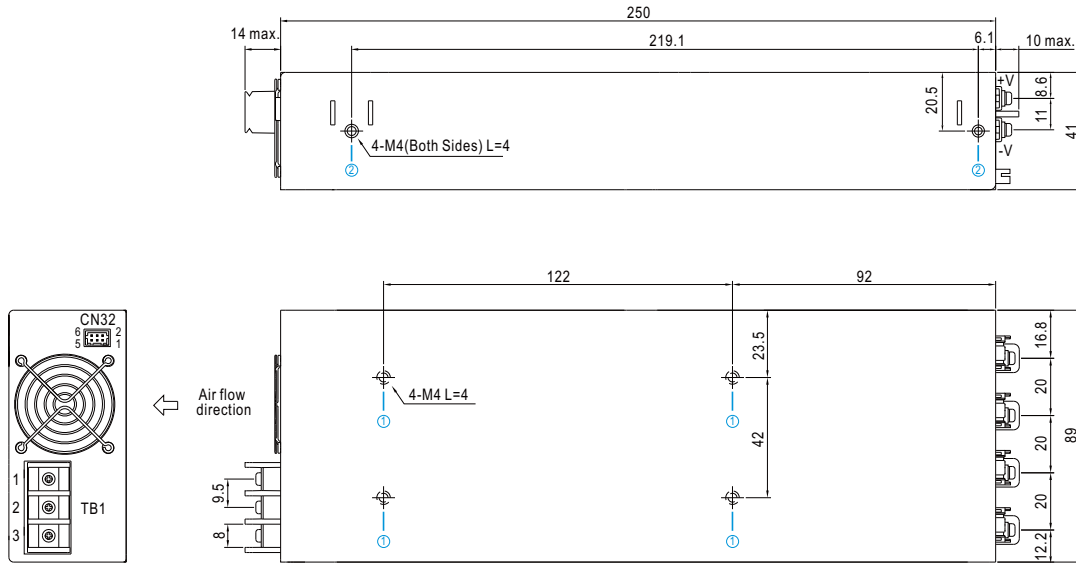

※ Mounting Instruction

Hole No.	Recommended Screw Size	MAX. Penetration Depth L	Recommended mounting torque
①	M4	4mm	7~10Kgf-cm
②	M4	4mm	7~10Kgf-cm

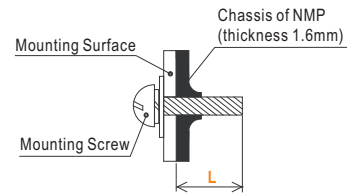

※AC Input Terminal Pin No. Assignment

Pin No.	Assignment	Diagram	Maximum mounting torque
1	FG ㏊		12Kgf-cm
2	AC/N		
3	AC/L		

■ **Function Description of CN32**

Pin No.	Function	Description
1,2	+5V-AUX_P	Auxiliary voltage output, 4.5~5.5V, referenced to pin 3 & 4(GND-P). The maximum load current is 2A(NMP1K2) or 1.5A(NMP650).
3,4	GND-P	Ground.
5	T-Alarm	TTL signal output for over temperature alarm. The maximum sourcing current is 10mA. High(4.5~5.5V) : When the internal temperature exceeds the limit & "safe limit" of temperature alarm. Low(0~0.5V) : When the internal temperature is normal.
6	RC1	Turns the output on and off by electrical or dry contact between pin 6(RC1) and pin 3 & 4(GND-P). Short : Power ON : Open : Power OFF.

■ **MECHANICAL SPECIFICATION**

※NMS-240 Output Module

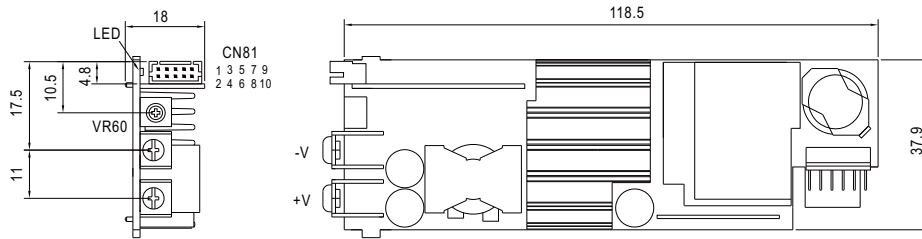

※Blank slot

Blank slot should be assembled with BLANK-NMS240, Please contact MEAN WELL for details.

※DC Output Terminal Pin No. Assignment

Assignment	Diagram	Maximum mounting torque	Recommended screw size	MAX. Penetration Depth L
+V, -V		10Kgf-cm	M3.5	10mm

■ **Function Description of CN81**

Pin No.	Function	Description
1	GND	Ground.
2	GND	Ground.
3	RC2	Turns the output on and off by electrical or dry contact between pin 3(RC2) and pin 1&2(GND). Open : Power ON : Short : Power OFF.
4	Vcc 2	Auxiliary voltage output, 4.5~5.5V, referenced to pin 1&2(GND). The maximum load current is 10mA.
5	DC OK	"DC OK" signal is a TTL level, referenced to pin 1&2(GND). Output modules turn on=4.5~5.5V, turn off=0~0.5V. The maximum sourcing current is 10mA(4.5~5.5V).
6	CS	Current sharing signal. When units are connected in parallel, the CS pins of the units should be connected to allow current balance between units. Referenced to pin 1&2(GND)
7	PC	Connection for output current programming, referenced to pin 1&2(GND)
8	PV	Connection for output voltage programming, referenced to pin 1&2(GND)
9	+S	Positive sensing for remote sense.
10	-S	Negative sensing for remote sense.

Function Manual

1. "Global ON/FF Control" function is not used

※ The power supply unit will have no output if the shorting connector (accessory comes along with the PSU) is not assembled. It contains one shorting wire: it is from RC1 (CN32 - PIN6) to GND-P (CN32 - PIN3)

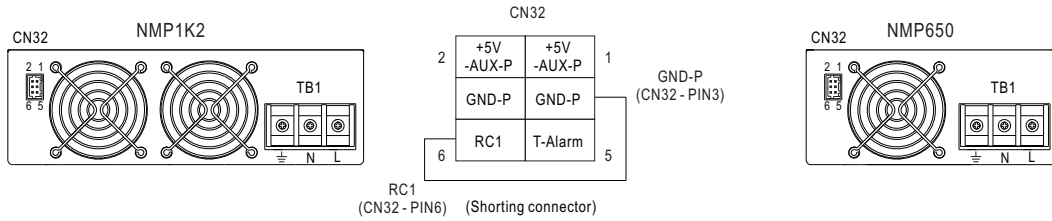

2. Global or Local ON/OFF CONTROL

※ The power supply can be turned ON/OFF for the entire unit, by global enable/inhibit, or for specific modules, by local Remote ON-OFF.

◎ Global ON/OFF

Between RC1(CN32-PIN6) and GND-P(CN32-PIN3)	Output Status
SW ON(short)	ON
SW OFF(open)	OFF

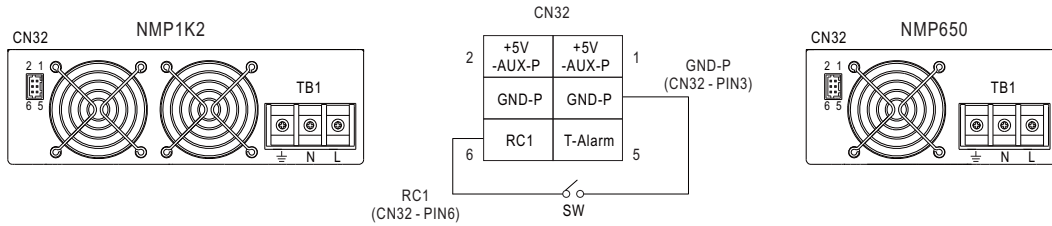

◎ Local ON/OFF

The NMS-240 can be turned ON/OFF by using the "local ON/OFF" function.

Between RC2(CN81-PIN3) and GND(CN81-PIN1 or 2)	Output Modules Status(NMS-240)
SW OFF(open)	ON
SW ON(short)	OFF

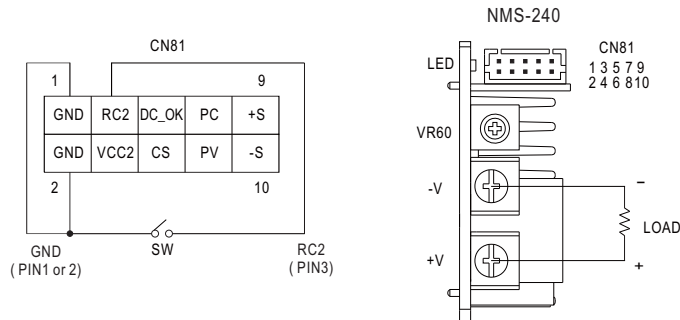

3. Remote Sense

※ The Remote Sense compensates voltage drop on the load wiring up to 0.5V.

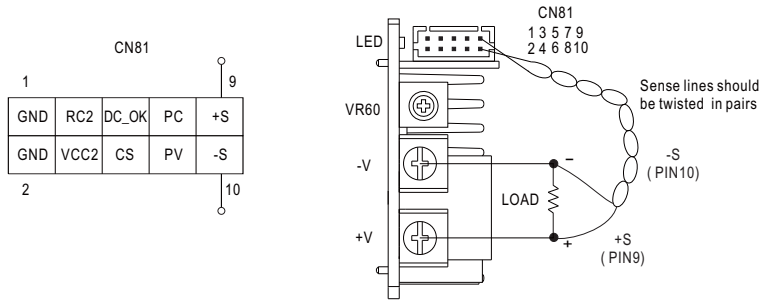

4. Output Voltage Programming(PV)

※ In addition to the adjustment via the built-in potentiometer, the output voltage (VR60 adjustable voltage) can be trimmed by applying "EXTERNAL VOLTAGE".

※ "Output Voltage Programming (PV)" range is the same to "Voltage ADJ. Range (VR60)"

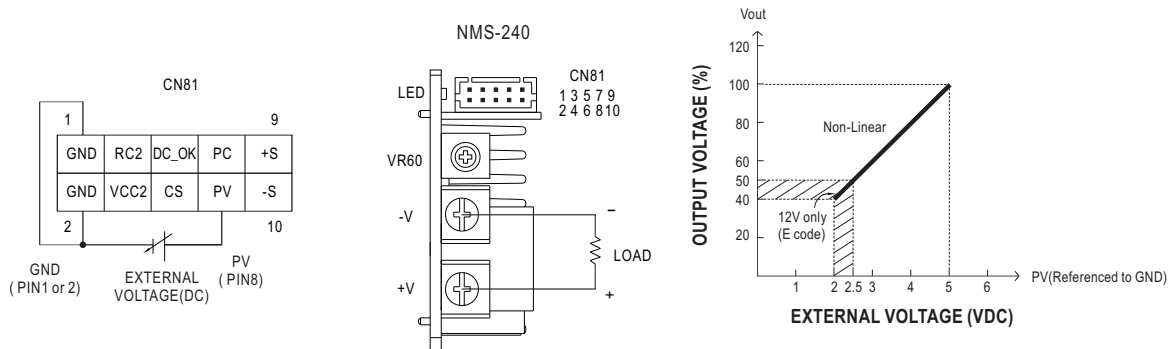

5. Constant Current Level Programming(PC)

※ The constant current level can be trimmed to 40~100% of the rated current by applying "EXTERNAL VOLTAGE".

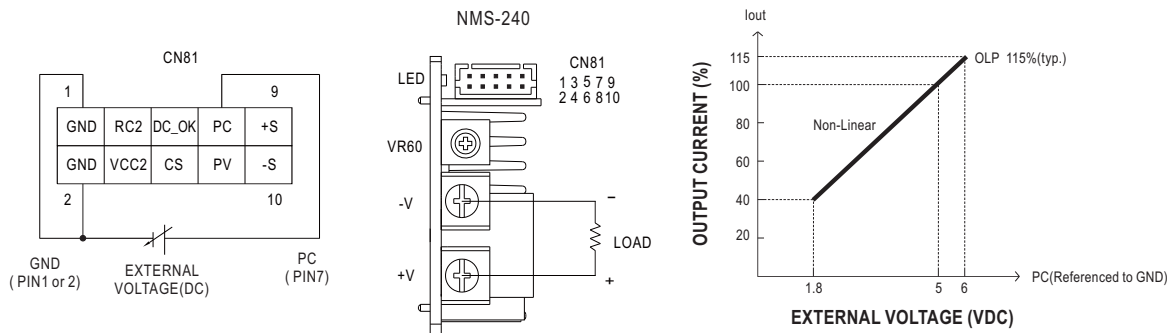

6. Auxiliary Power

※ +5V-Aux_P : Aux. power is 5V/2A(NMP1K2).
 Aux. power is 5V/1.5A(NMP650).

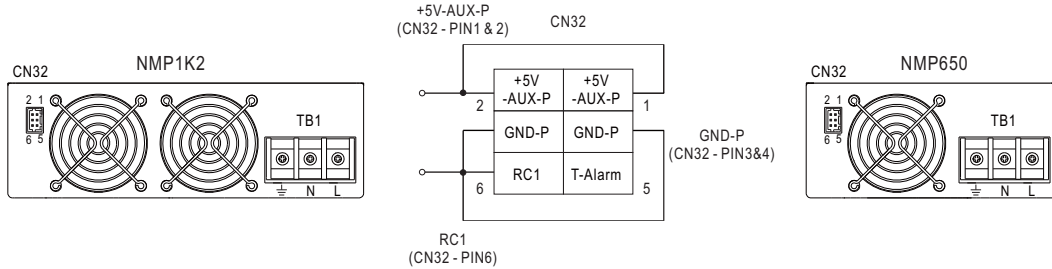

※ Vcc2 : Aux. Power is 5V/10mA(Output Modules)

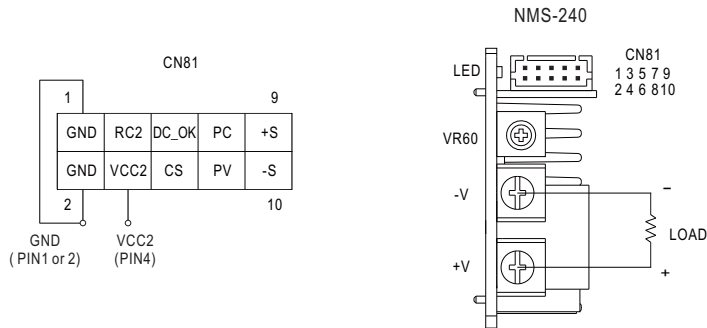

7. DC OK Signal

"DC OK" signal is a TTL level signal. It indicates the output status of the output modules. "High" when module turns on.
 The maximum sourcing current is 10mA(4.5~5.5V).

Between DC OK(PIN 5) and GND(PIN 1 or 2)	Output Modules Status (NMS-240)
4.5~5.5V	ON
0~0.5V	OFF

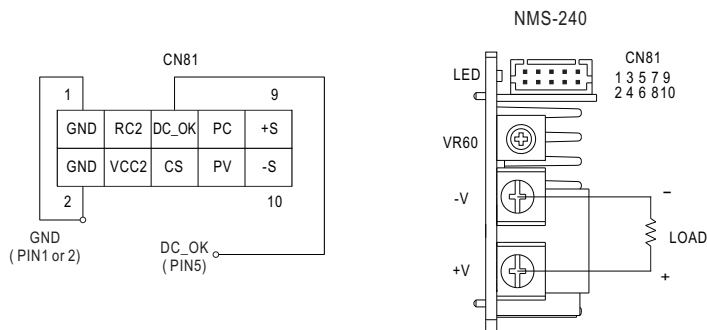

8. T-Alarm Signal

TTL signal output for over temperature alarm. The maximum sourcing current is 10mA.

Between T-Alarm(CN32 PIN 5) and GND-P(CN32 PIN 3 or 4)	Internal temperature (U702)	Output Status
0~0.5V	The internal temperature is normal.	ON
4.5~5.5V	Exceeds the limit of temperature alarm.	ON
4.5~5.5V	Exceeds the "safe limit" of temperature alarm.	OFF

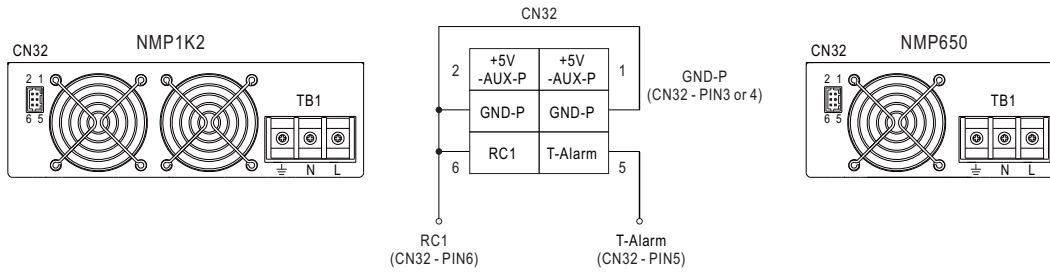

9. CURRENT SHARING(CS)

- Parallel operation is available by connecting the NMS-240 shown as below (CS, GND are connected mutually in parallel).
- Difference of output voltages among parallel NMS-240 should be less than 0.2V.
- The total output current must not exceed the value determined by the following equation (Output current at parallel operation)

$$= (\text{The rated current per NMS-240}) \times (\text{Number of NMS-240}) \leq \text{TOTAL output power (NMP650 is 650W max. ; NMP1K2 is 1200W max.)}$$
- In parallel operation 4 or 6 NMS-240(NMP650 is 4 SLOT ; NMP1K2 is 6 SLOT) is the maximum, please consult the manufacture for other applications.
- The power supplies should be paralleled using short and large diameter wiring and then connected to the load.
- In parallel connection, maybe only one NMS-240 (master) operate if the total output load is less than 10% of rated load condition.

The other NMS-240 (slaves) may go into standby mode.

- ※ NMS-240 * 6 SLOT maximum(NMP1K2) 、 NMS-240 * 4 SLOT maximum(NMP650).
- ※ The overload protection of C module (5V) for current sharing is Hiccup mode.
- ※ Paralled or series connection accessory, Please contact MEAN WELL for details.

